

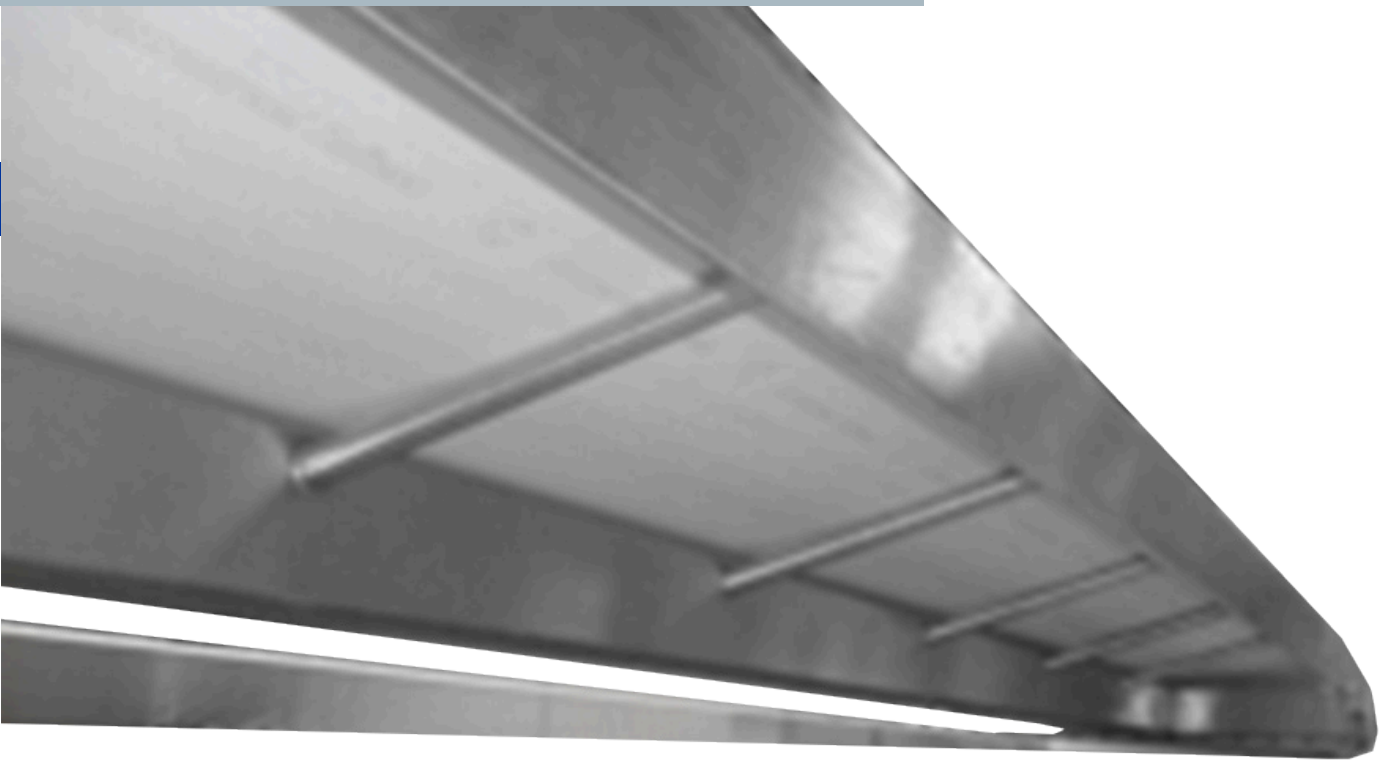

**FOOD MACHINERY  
ENGINEERING LTD**

**BETTER BY DESIGN**

# OVERHEAD CONVEYORS



**BUILT TO LAST FOREVER**

**#8 19158 94TH AVE  
SURREY, BC V4N 4X8**

**PHONE: (604) 888-8686  
TOLL FREE: (877) 700-8686**

**FAX: (604) 888-8638  
EMAIL: [info@fmefoodmachinery.com](mailto:info@fmefoodmachinery.com)**

# FME OVERHEAD CONVEYORS

## STANDARD FEATURES

- Conveyor belt width of 28 inches with 31.5 inch wide pulleys
- Open cantilever mounting design for easy belt installation
- UHMW belt scraper assembly at one end for standard one way transport or both ends for reversing operation
- Optional inner pulley scrapers ensure continuous pulley and belt cleaning for positive belt tracking

Overhead Conveyor package includes ceiling support hangers of 4x4 stainless steel tube for each conveyor (does not include hanger rods or roof support structure)

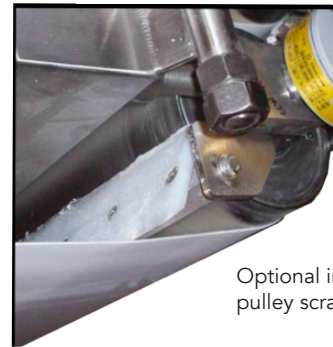

Optional inner pulley scrapers

## ALLERGEN ACCESS OVERHEAD CONVEYORS



Allergen Access Conveyor Design

Built to the highest standards for tracking and dough handling, FME's Allergen Access Overhead Conveyors provide fast and low cost sanitation.

With 28 inch wide belts, 31.5 inch wide pulleys, and outer frame sides, these conveyors are completely open for allergen access and removal.

### SHORT OVERHEAD CONVEYOR (MAX 20 FT)

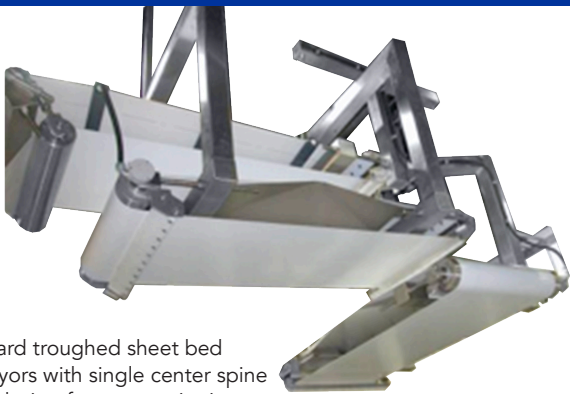

Standard troughed sheet bed conveyors with single center spine open design for easy sanitation

### LONG OVERHEAD CONVEYOR (20-50 FT)

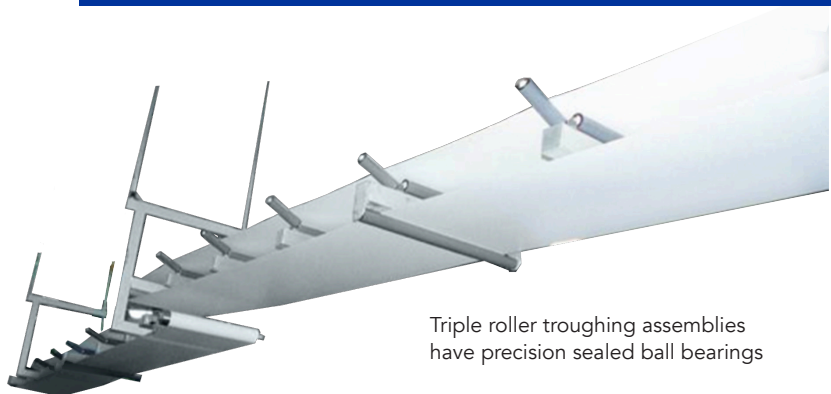

Triple roller troughing assemblies have precision sealed ball bearings



#8 19158 94TH AVE  
SURREY, BC V4N 4X8

PHONE: (604) 888-8686  
TOLL FREE: (877) 700-8686

FAX: (604) 888-8638  
EMAIL: [info@fmefoodmachinery.com](mailto:info@fmefoodmachinery.com)